

Warewashing
Extrasmall Single Skin GW, drain pump
& detergent & rinse aid dispenser, 30b/h

ITEM # _____

MODEL # _____

NAME # _____

SIS # _____

AIA # _____

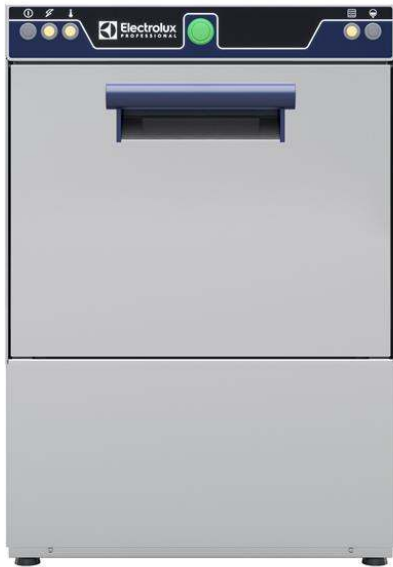
402275 (EXSG)

Glasswasher (extrasmall), with single skin, built-in drain pump and detergent and rinse aid dispenser, 1 cycle, 30b/h

Short Form Specification

Item No. _____

Unit shall be Glasswasher type hot water rinsing for rack dimension from 350*350mm up to 380*380mm. Electrical characteristics to be 230 single phase operation with one wash cycle of 120 seconds. Rinse temperature and pressure guaranteed by built in pressure boiler. Washing performance is ensured by a powerful wash pump, revolving washing spray arms. Double skinned counter-balance door. 304 stainless steel construction to include door, frame, wash tank, wash arm and rinse arms. The unit shall include drain pump, detergent and rinse aid dispenser pump and be equipped with electric cable with Schuko plug.

Main Features

- Deep drawn pressed wash tank with fully rounded corners, sloped towards the drain to prevent dirt build up provides fast drainage in only a few minutes. Pressed wash tank with no welded points offer a guaranteed water tight solution.
- 120 seconds cycle.
- Built-in pressure boiler designed to raise incoming water to a guaranteed minimum temperature of 82° C for sanitizing rinse. No external boiler is required.
- Maximum capacity of 30 racks per hour.
- Equipped with single phase electrical cable and Schuko plug for easy and fast installation.
- Easy service access to main components without moving the unit.
- Built-in rinse aid and detergent dispenser with automatic initial and continuous cycle loading for perfect result while minimizing service and maintenance needs.
- Equipped with drain pump for easy and quick installation without opening the machine.
- Washing system endowed with rotating washing arms, high powered wash pump and large capacity wash tank for professional washing.
- Flexible rack support suitable to use rack dimension from 350x350mm up to 380x380mm.

Construction

- Completely closed on the back by a cover plate.
- Internal components (arms and filter) are easy extractable.
- Unit to feature rinse aid and detergent dispenser pumps.
- Robust structure thanks to stainless steel construction.

Sustainability



- Simple operation control panel.
- Insulated double skin door construction preserves heat inside the tank to lower energy consumption and the noise. Counter-balance mechanism minimizes impact when opening and closing.
- Finished in top quality materials to ensure durability.

APPROVAL: _____



Included Accessories

- 1 of Square basket for glasses, 380x380x150mm PNC 867036
- 1 of Round basket for glasses, 400x180mm PNC 867047
- 1 of Insert for 12 saucers, 290X90x75mm PNC 867048

Optional Accessories

- Square basket for glasses, 350x350x150mm PNC 867034
- Round basket for glasses, 350x160mm PNC 867035
- Round basket for glasses, 380x170mm PNC 867037
- Kit detergent dispenser for Single Skin XS and Single Skin S Glasswasher PNC 867072



Front

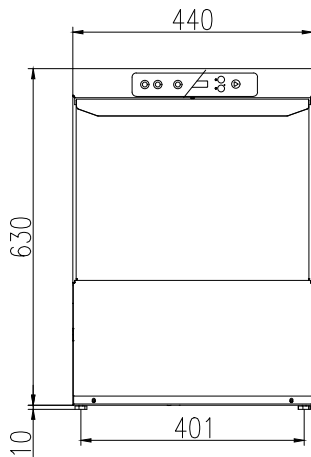

Side

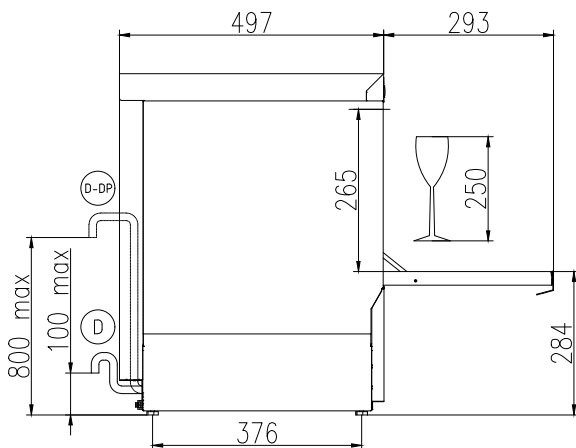

CWII = Cold Water inlet 1 (cleaning) XR = Rinse aid connection
 D = Drain
 EI = Electrical inlet (power)
 EO = Electrical Outlet
 WI = Water inlet
 XD = Detergent connection

Rear side

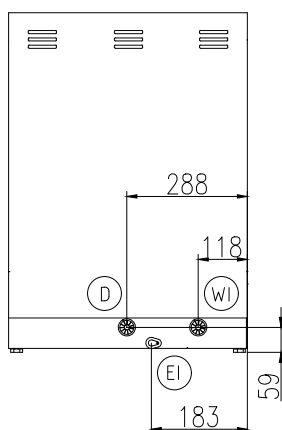

Electric

Supply voltage:	
402275 (EXSG)	220-240 V/1 ph/50 Hz
Default Installed Power:	0 kW
Boiler heating elements:	2.7 kW
Tank heating elements:	2.4 kW
Wash pump size:	0.2 kW

Water:

Pressure, bar min/max:	2-5 bar
Water supply temperature*:	10-50 °C
Drain line size:	29mm
Washing tank capacity (lt):	ISO 9001; ISO 14001
Water consumption per cycle (lt):	0
Boiler Capacity (lt):	3
Incoming water line size:	3/4"

Key Information:

Baskets per hour (cycle 1/ MyEco/Fast*):	0 / 0 /
Working cycles time (sec.):	
Wash temperature:	
Cell dimensions - width:	390 mm
Cell dimensions - depth:	386 mm
Cell dimensions - height:	265 mm
Rinse temperature:	85 °C
External dimensions, Width:	440 mm
External dimensions, Depth:	497 mm
External dimensions, Height:	640 mm
Net weight:	35 kg
Shipping weight:	39 kg
Shipping height:	790 mm
Shipping width:	530 mm
Shipping depth:	590 mm
Shipping volume:	0.25 m ³

Sustainability

Noise level: